

## BV12-2425E-PN10 - Wormwielkast

Lug type vlinderklep, te monteren tussen flenzen PN10, met wormwielkast

Norm Bouwlengte: EN 558-1 Tabel 1 serie 20



Artikelnummer	Belven Ref.
121023E3200	BV12-2425E-PN10-DN200 - GEARBOX
121023E3250	BV12-2425E-PN10-DN250 - GEARBOX
121023E3300	BV12-2425E-PN10-DN300 - GEARBOX

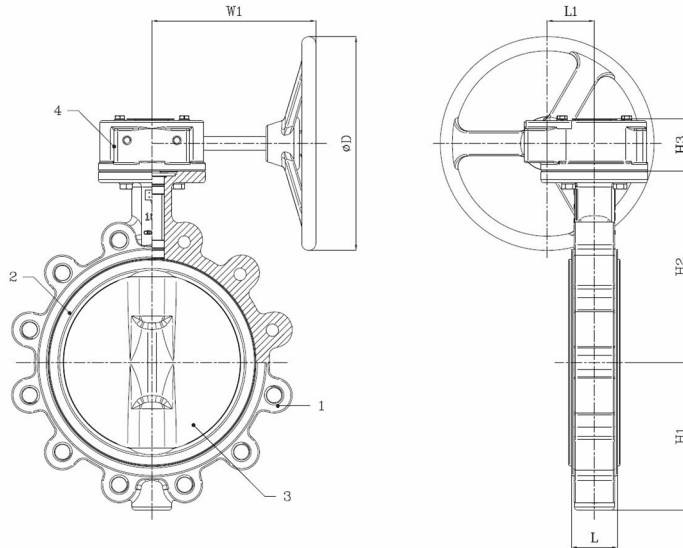

DN/Inch	L	H1	H2	H3	L1	D	W1	Drukkl.	Gewicht(kg)
DN200 (8")	60	168	237	80,5	63	300	237	PN10	26,50
DN250 (10")	68	207	268,3	80,5	63	300	237	PN10	36,50
DN300 (12")	78	243,5	308,5	80,5	78	300	225	PN10	67,00

Item 1	Item 2	Item 3	Item 4
<b>Materiaal Huis</b>	<b>Materiaal Zitting</b>	<b>Materiaal Klepblad</b>	<b>Materiaal Bediening</b>
Nodulair gietijzer : GGG40 + Epoxy coating	EPDM	Vernikkeld : GGG40 + Ni	Gietijzer