

## BV10NPA-2466E-PN10/PN16 - Aluminium

### Wormwielkast

Wafer type vlinderklep, te monteren tussen flenzen PN10/PN16, met aluminium wormwielkast

Norm Bouwlengte: EN 558-1 Tabel 1 serie 20



Artikelnummer	Belven Ref.
10HCD226E5A0200	BV10NPA-2466E-PN16-DN200 - ALU GEARBOX
10HCD226E5A0250	BV10NPA-2466E-PN16-DN250 - ALU GEARBOX
10HCD226E5A0300	BV10NPA-2466E-PN16-DN300 - ALU GEARBOX

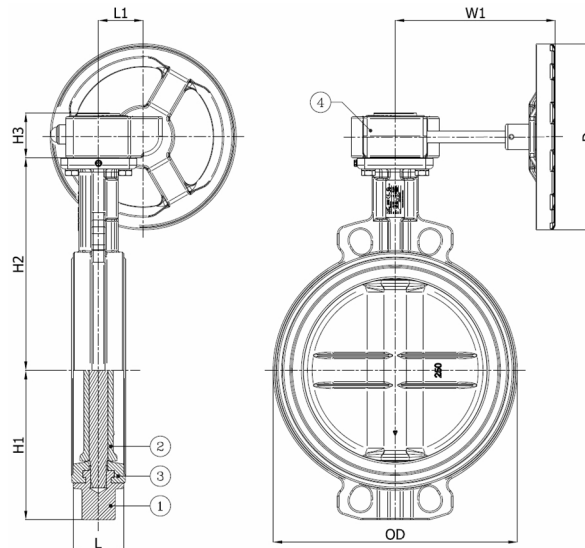

DN/Inch	L	H1	H2	H3	OD	L1	D	W1	Drukl.	Gewicht(kg)
DN200 (8")	60	165	240	58	259	60	250	215	PN16	17,00
DN250 (10")	68	201	286	58	320	60	250	215	PN16	24,70
DN300 (12")	78	234	309	58	370	60	250	215	PN16	36,00

Item 1	Item 2	Item 3	Item 4
Materiaal Huis	Materiaal Zitting	Materiaal Klepblad	Materiaal Bediening
Nodulair gietijzer : GGG40 + Epoxy coating	EPDM	Roestvrijstaal : CF8M	Aluminium