

BV10S-GAS-2425NG-PN10/PN16/A150 - Hendel

DVGW gekeurd

Wafer type vlinderklep, te monteren tussen flenzen PN10/PN16/A150, met vergendelbare hendel, DVGW Gas gekeurd volgens EN 13774:2013

Norm Bouwlengthe: EN 558-1 Tabel 1 serie 20

Met NBR-GAS zitting volgens EN 682



Artikelnummer	Belven Ref.
10SOG3044NG10050	BV10S-GAS-2425NG-PN16-DN050 - LEVER
10SOG3044NG10065	BV10S-GAS-2425NG-PN16-DN065 - LEVER
10SOG3044NG10080	BV10S-GAS-2425NG-PN16-DN080 - LEVER
10SOG3044NG10100	BV10S-GAS-2425NG-PN16-DN100 - LEVER
10SOG3044NG10125	BV10S-GAS-2425NG-PN16-DN125 - LEVER
10SOG3044NG10150	BV10S-GAS-2425NG-PN16-DN150 - LEVER

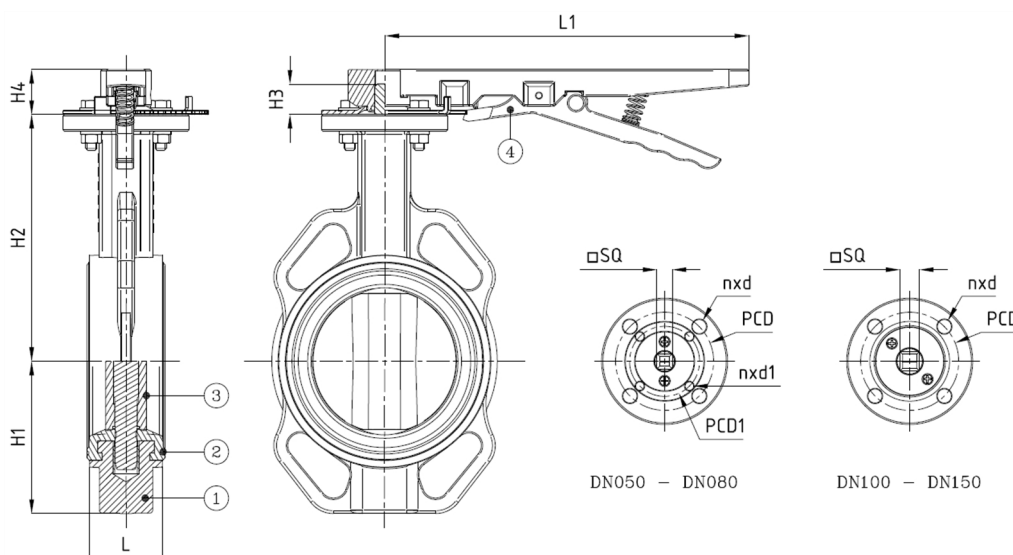

DN/Inch	L	H1	H2	H3	H4	L1	SQ	ISO	PCD	n x d1	PCD1	ISO1	n x d	Drukl.	Gewicht(kg)
DN050 (2")	43	64	140,5	22	29	260	11	F05	50	4 x d10	70	F07	4 x d7	PN16	4,00
DN065 (2 1/2")	46	71,4	152,5	22	29	260	11	F05	50	4 x d10	70	F07	4 x d7	PN16	4,70
DN080 (3")	46	94	157,5	22	29	260	11	F05	50	4 x d10	70	F07	4 x d7	PN16	5,10
DN100 (4")	52	108,5	176	22	29	260	14	F07	70	4 x d10				PN16	6,60
DN125 (5")	56	119	191	22	29	260	14	F07	70	4 x d10				PN16	8,40
DN150 (6")	56	136	202,5	22	29	260	14	F07	70	4 x d10				PN16	9,90

Item 1	Item 2	Item 3	Item 4
Materiaal Huis	Materiaal Zitting	Materiaal Klepblad	Materiaal Bediening
Nodulair gietijzer : GGG40 + Epoxy coating	NBR-GAS	Vernikkeld : GGG40 + Ni	Gietijzer