

BV3M3-2466T-BSP - DSTE met Hendel

3-delige kogelkraan, volle doorlaat, BSP draadeinden V/V ISO 228/1-G, ISO 5211 verhoogde top flens, inclusief RVS spindelverlenging met schutbuis en vergrendelbare hendel

Norm Bouw lengte: DIN 3202-4 M3



| Artikelnummer | Belven Ref. |
|----------------|---------------------------------------|
| 03M36156T1S008 | BV3M3-2466T-BSP - 1/4" - DSTE-LEVER |
| 03M36156T1S010 | BV3M3-2466T-BSP - 3/8" - DSTE-LEVER |
| 03M36156T1S015 | BV3M3-2466T-BSP - 1/2" - DSTE-LEVER |
| 03M36156T1S020 | BV3M3-2466T-BSP - 3/4" - DSTE-LEVER |
| 03M36156T1S025 | BV3M3-2466T-BSP - 1" - DSTE-LEVER |
| 03M36156T1S032 | BV3M3-2466T-BSP - 1 1/4" - DSTE-LEVER |
| 03M36156T1S040 | BV3M3-2466T-BSP - 1 1/2" - DSTE-LEVER |
| 03M36156T1S050 | BV3M3-2466T-BSP - 2" - DSTE-LEVER |

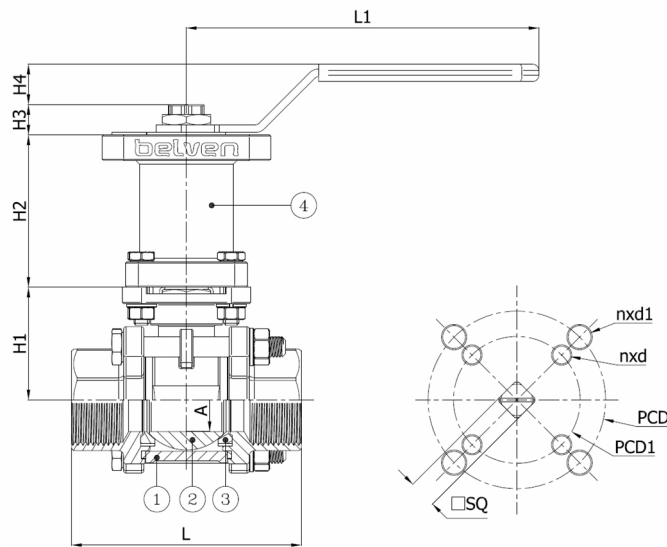

| DN/Inch | L | H1 | H2 | H3 | H4 | A | L1 | SQ | ISO | PCD | n x d1 | PCD1 | ISO1 | n x d | Drukkl. | Gewicht(kg) |
|----------------|-----|------|----|------|------|------|-----|----|-----|-----|--------|------|------|-------|----------|-------------|
| DN008 (1/4") | 55 | 36 | 58 | 9,6 | 15,5 | 11,6 | 112 | 11 | F05 | 50 | | | | 4 x 7 | 1000 WOG | 1,30 |
| DN010 (3/8") | 60 | 36 | 58 | 9,6 | 15,5 | 12,8 | 112 | 11 | F05 | 50 | | | | 4 x 7 | 1000 WOG | 1,30 |
| DN015 (1/2") | 75 | 38 | 58 | 9,6 | 15,5 | 15 | 112 | 11 | F05 | 50 | | | | 4 x 7 | 1000 WOG | 1,40 |
| DN020 (3/4") | 80 | 41,7 | 60 | 11,6 | 17,3 | 20 | 138 | 14 | F05 | 50 | 4 x 9 | 70 | F07 | 4 x 7 | 1000 WOG | 1,60 |
| DN025 (1") | 90 | 44,4 | 60 | 11,6 | 17,3 | 25 | 138 | 14 | F05 | 50 | 4 x 9 | 70 | F07 | 4 x 7 | 1000 WOG | 1,80 |
| DN032 (1 1/4") | 110 | 52,8 | 60 | 11,2 | 24,4 | 32 | 205 | 14 | F07 | 70 | 4 x 9 | 70 | F07 | 4 x 9 | 1000 WOG | 2,70 |
| DN040 (1 1/2") | 120 | 58,5 | 60 | 11,2 | 24,4 | 38 | 205 | 14 | F07 | 70 | 4 x 9 | 70 | F07 | 4 x 9 | 1000 WOG | 3,40 |
| DN050 (2") | 140 | 66 | 60 | 11,2 | 24,4 | 50 | 205 | 14 | F07 | 70 | 4 x 9 | 70 | F07 | 4 x 9 | 1000 WOG | 4,60 |

| Item 1 | Item 2 | Item 3 | Item 4 |
|--------------------------|---------------------------|-------------------|-------------------------|
| Materiaal Huis | Materiaal Kogel | Materiaal Zitting | Materiaal Bediening |
| Koolstofstaal : A216 WCB | Roestvrijstaal : A351 CF8 | PTFE | Roestvrijstaal AISI 316 |