

BV4-4766T-A150 - DSTE met Hendel

Kogelkraan, volle doorlaat, tweedelijg huis, geflensd ANSI 150lbs, inclusief RVS spindelverlenging met schutbuis en hendel
Norm Bouwlengte: ANSI B16.10

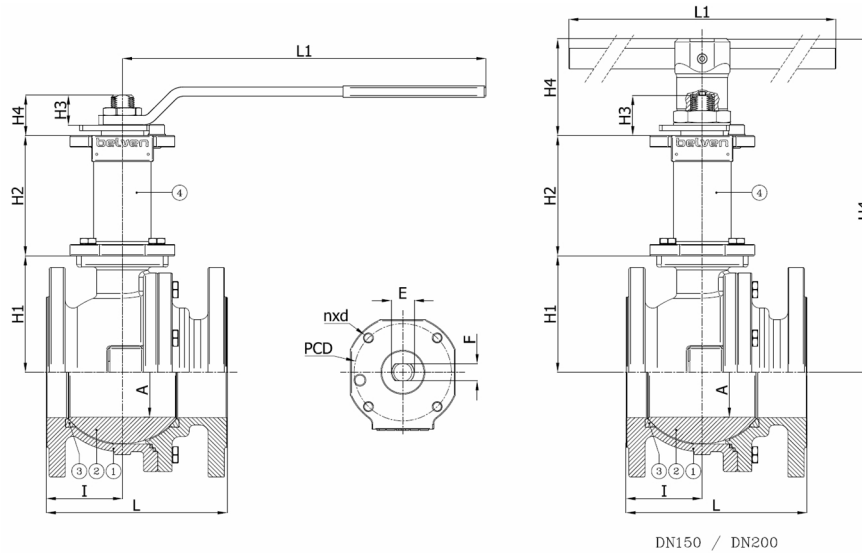

Artikelnummer	Belven Ref.
047A07DSTE1015	BV4-4766T-A150-DN015 - DSTE-LEVER
047A07DSTE1020	BV4-4766T-A150-DN020 - DSTE-LEVER
047A07DSTE1025	BV4-4766T-A150-DN025 - DSTE-LEVER
047A07DSTE1040	BV4-4766T-A150-DN040 - DSTE-LEVER
047A07DSTE1050	BV4-4766T-A150-DN050 - DSTE-LEVER
047A07DSTE1080	BV4-4766T-A150-DN080 - DSTE-LEVER
047A07DSTE1100	BV4-4766T-A150-DN100 - DSTE-LEVER
047A07DSTE1150	BV4-4766T-A150-DN150 - DSTE-LEVER
047A07DSTE1200	BV4-4766T-A150-DN200 - DSTE-LEVER



DN150 / DN200

DN/Inch	L	H1	H2	H3	H4	I	L1	E	F	ISO	PCD	n x d	Drukkl.	Gewicht(kg)
DN015 (1/2")	108	33	110	8	51,5	46,5	131	M10	7	F04	42	4 x M5	A150	2,80
DN020 (3/4")	117	37	110	8	51	53	131	M10	7	F04	42	4 x M5	A150	3,30
DN025 (1")	127	45	113	13	37	59,5	174	M12	8	F05	50	4 x M6	A150	4,80
DN040 (1 1/2")	165	77	113	10	44,1	77	250	M16	10	F05	50	4 x M6	A150	8,10
DN050 (2")	178	83,5	121	18	51,8	86	321	M20	14	F07	70	4 x M8	A150	12,70
DN080 (3")	203	108	126	18	52,7	79,5	381	M24	18	F10	102	4 x M10	A150	24,10
DN100 (4")	229	122	126	18	52,7	110	381	M24	18	F10	102	4 x M10	A150	32,60
DN150 (6")	394	177	145	27,5	120,5	181	700	M42	30	F12	125	4 x M12	A150	86,00
DN200 (8")	457	220	145	27,5	120,5	212	700	M42	30	F12	125	4 x M12	A150	161,00

Item 1	Item 2	Item 3	Item 4
Materiaal Huis	Materiaal Kogel	Materiaal Zitting	Materiaal Bediening
Lage-temperatuur staal : A352 LCB	Roestvrijstaal : A182-F304 / A351-CF8	PTFE	Roestvrijstaal AISI 316