

BV12-2466E-PN10 - Aluminium Wormwielkast

Lug type vlinderklep, te monteren tussen flenzen PN10, met aluminium wormwielkast

Norm Bouwlengte: EN 558-1 Tabel 1 serie 20



Artikelnummer	Belven Ref.
121026E5A200	BV12-2466E-PN10-DN200 - ALU GEARBOX
121026E5A250	BV12-2466E-PN10-DN250 - ALU GEARBOX
121026E5A300	BV12-2466E-PN10-DN300 - ALU GEARBOX

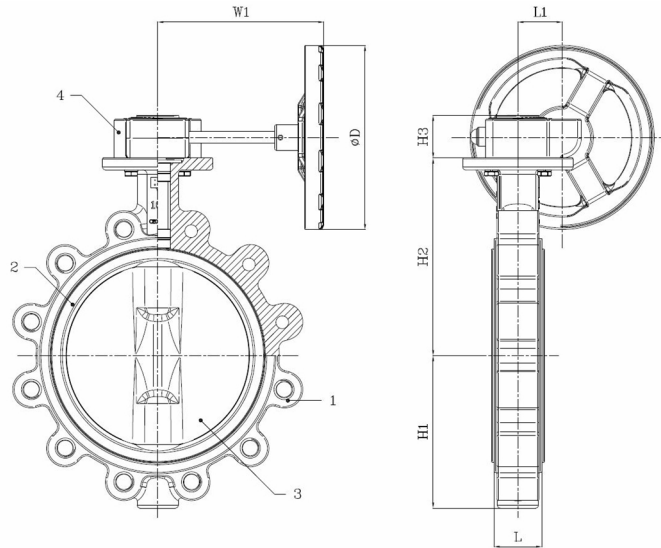

DN/Inch	L	H1	H2	H3	L1	D	W1	Drukkl.	Gewicht(kg)
DN200 (8")	60	168	237	60	60	250	225,5	PN10	17,50
DN250 (10")	68	207	268,3	60	60	250	225,5	PN10	33,10
DN300 (12")	78	243,5	308,5	87	81	400	263	PN10	58,20

Item 1	Item 2	Item 3	Item 4
Materiaal Huis	Materiaal Zitting	Materiaal Klepblad	Materiaal Bediening
Nodulair gietijzer : GGG40 + Epoxy coating	EPDM	Roestvrijstaal : CF8M	Aluminium