

BV10SA-GAS-2425NG-PN10/PN16/A150 - Wormwielkast DVGW gekeurd

Wafer type vlinderklep, ATEX, te monteren tussen flenzen PN10/PN16/A150, met wormwielkast, DVGW Gas gekeurd volgens EN 13774:2013

Norm Bouwlengte: EN 558-1 Tabel 1 serie 20

Met NBR-GAS zitting volgens EN 682



Artikelnummer	Belven Ref.
10SAG3044NG30200	BV10SA-GAS-2425NG-PN16-DN200 - GEARBOX
10SAG3044NG30250	BV10SA-GAS-2425NG-PN16-DN250 - GEARBOX
10SAG3044NG30300	BV10SA-GAS-2425NG-PN16-DN300 - GEARBOX

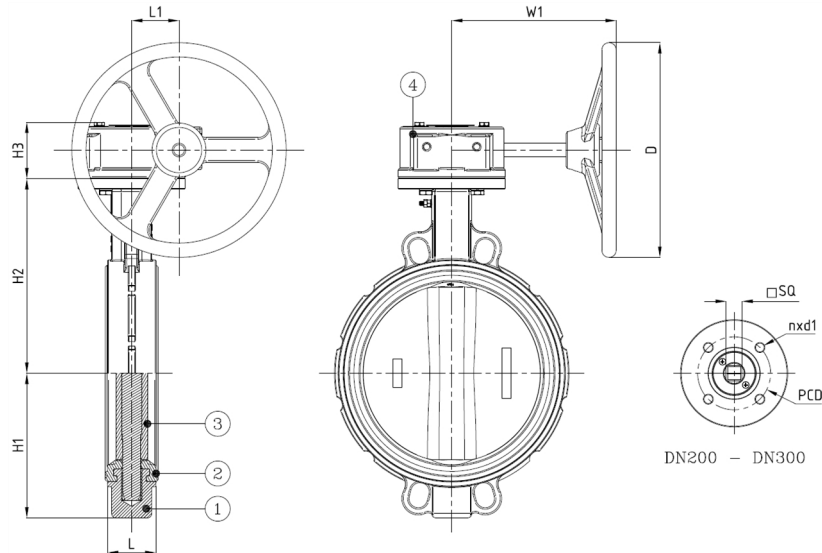

DN/Inch	L	H1	H2	H3	L1	SQ	ISO	PCD	n x d1	D	W1	Drukl.	Gewicht(kg)
DN200 (8")	60	165	243,5	80,5	63	17	F10	102	4 x d12	300	237	PN16	25,20
DN250 (10")	68	202	273	80,5	63	22	F10	102	4 x d12	300	237	PN16	32,10
DN300 (12")	78	235	311	80,5	78	27	F12	125	4 x d14	300	225	PN16	44,70

Item 1	Item 2	Item 3	Item 4
Materiaal Huis	Materiaal Zitting	Materiaal Klepblad	Materiaal Bediening
Nodulair gietijzer : GGG40 + Epoxy coating	NBR-GAS	Vernikkeld : GGG40 + Ni	Gietijzer