

BV12SA-2466V-PN10 - Hendel

Lug type vlinderklep, ATEX, te monteren tussen flenzen PN10, met vergrendelbare hendel

Norm Bouwlengte: EN 558-1 Tabel 1 serie 20

Zitting uit FPM(Viton), max. werkdruk 16 bar, -5°C tot 200°C



Artikelnummer	Belven Ref.
12SA02047V10200	BV12SA-2466V-PN10-DN200 - LEVER
12SA02047V10250	BV12SA-2466V-PN10-DN250 - LEVER
12SA02047V10300	BV12SA-2466V-PN10-DN300 - LEVER

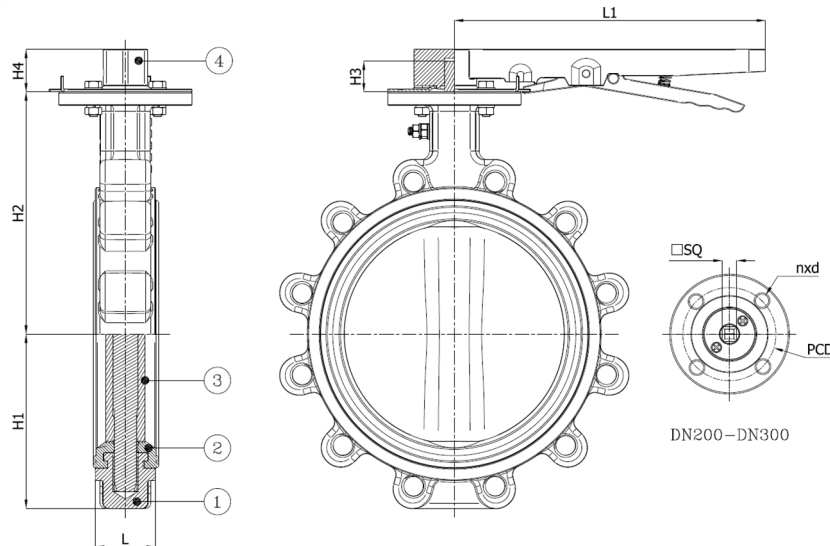

DN/Inch	L	H1	H2	H3	H4	L1	SQ	ISO	PCD	n x d1	Drukl.	Gewicht(kg)
DN200 (8")	60	165	243,5	34,5	45	350	17	F10	102	4 x d12	PN10	21,50
DN250 (10")	68	202	273	34,5	45	350	22	F10	102	4 x d12	PN10	32,00
DN300 (12")	78	235	311	34,5	45	350	27	F12	125	4 x d14	PN10	50,50

Item 1	Item 2	Item 3	Item 4
Materiaal Huis	Materiaal Zitting	Materiaal Klepblad	Materiaal Bediening
Nodulair gietijzer : GGG40 + Epoxy coating	FPM	Roestvrijstaal : CF8M	Gietijzer