

## BV3M3-6666T-BW - Electrisch 110/240V AC

3-delige kogelkraan, volle doorlaat, laseinden BW ASME B16.25 Sched.40, met elektrische aandrijving  
Norm Bouwlenge: DIN 3202-2 S13

De pneumaat is geselecteerd voor 20°C water met een drukval van 6 bar en minimum 1 schakeling per week - 110/240V AC



Artikelnummer	Belven Ref.
03M36877TEL008	BV3M3-6666T-BW - 1/4" - VB015 110/240VAC
03M36877TEL010	BV3M3-6666T-BW - 3/8" - VB015 110/240VAC
03M36877TEL015	BV3M3-6666T-BW - 1/2" - VB015 110/240VAC
03M36877TEL020	BV3M3-6666T-BW - 3/4" - VB015 110/240VAC
03M36877TEL025	BV3M3-6666T-BW - 1" - VB030 110/240VAC
03M36877TEL032	BV3M3-6666T-BW - 1 1/4" - VB060 110/240VAC
03M36877TEL040	BV3M3-6666T-BW - 1 1/2" - VB060 110/240VAC
03M36877TEL050	BV3M3-6666T-BW - 2" - VB060 110/240VAC

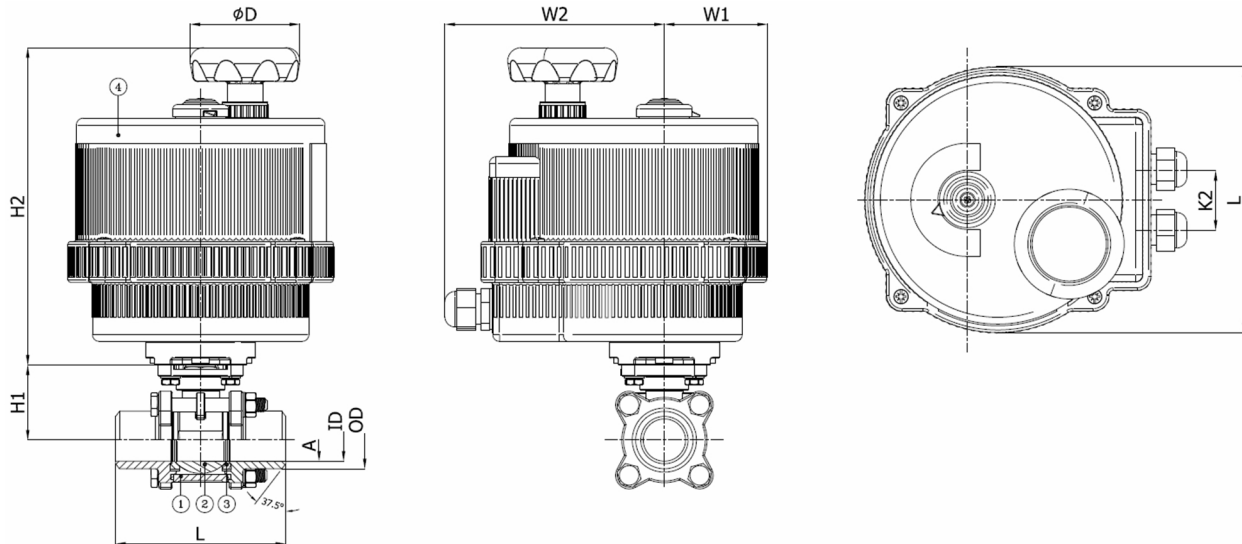

DN/Inch	L	H1	H2	A	L1	ID	OD	W1	W2	D	K2	Drukkl.	Gewicht(kg)
DN008 (1/4")	55	36	141,5	11,6	123	11,6	18,1	42,5	120,5	68	32	1000 WOG	1,87
DN010 (3/8")	60	36	141,5	12,8	123	12,8	18,1	42,5	120,5	68	32	1000 WOG	1,87
DN015 (1/2")	75	38	141,5	15	123	15	21,7	42,5	120,5	68	32	1000 WOG	2,01
DN020 (3/4")	90	41,7	141,5	20	123	20	27,2	42,5	120,5	68	32	1000 WOG	2,27
DN025 (1")	100	44,4	188	25	157	25	34	60,5	129,5	65	36	1000 WOG	3,38
DN032 (1 1/4")	110	52,8	215	32	185	32	42,7	67,5	146,5	65	36	1000 WOG	5,10
DN040 (1 1/2")	125	58,5	215	38	185	38	48,6	67,5	146,5	65	36	1000 WOG	5,76
DN050 (2")	150	66	215	50	185	50	60,5	67,5	146,5	65	36	1000 WOG	6,96

Item 1	Item 2	Item 3	Item 4
<b>Materiaal Huis</b>	<b>Materiaal Kogel</b>	<b>Materiaal Zitting</b>	<b>Materiaal Bediening</b>
Roestvrijstaal : A351 CF8M	Roestvrijstaal : A351 CF8M	PTFE	Geëxtrudeerd aluminium