

BV10-2366E-PN10/PN16/A150 - Vrije As

Wafer type vlinderklep, te monteren tussen flenzen PN10/PN16/A150, vrije as
Norm Bouw lengte: EN 558-1 Tabel 1 serie 20

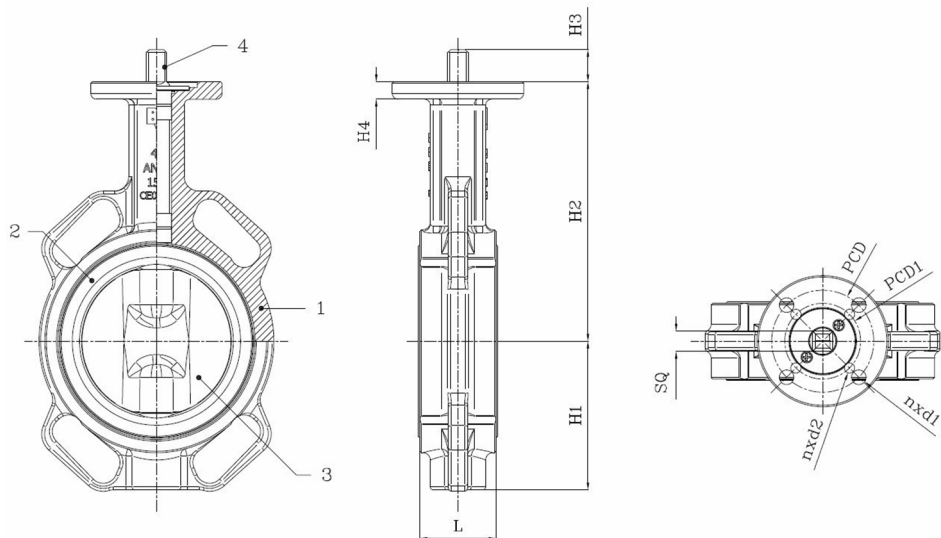

Artikelnummer	Belven Ref.
101026E0050	BV10-2366E-PN16-DN050 - BARE SHAFT
101026E0065	BV10-2366E-PN16-DN065 - BARE SHAFT
101026E0080	BV10-2366E-PN16-DN080 - BARE SHAFT
101026E0100	BV10-2366E-PN16-DN100 - BARE SHAFT
101026E0125	BV10-2366E-PN16-DN125 - BARE SHAFT
101026E0150	BV10-2366E-PN16-DN150 - BARE SHAFT
101026E0200	BV10-2366E-PN16-DN200 - BARE SHAFT
101026E0250	BV10-2366E-PN16-DN250 - BARE SHAFT
101026E0300	BV10-2366E-PN16-DN300 - BARE SHAFT



DN/Inch	L	H1	H2	H3	H4	SQ	ISO	PCD	n x d1	n x d2	PCD1	Drukkl.	Gewicht(kg)
DN050 (2")	43	71,4	142,7	22	12	11	F05/F07	70	4 x d10	4 x d7	50	PN16	2,60
DN065 (2 1/2")	46	77,8	155,4	22	12	11	F05/F07	70	4 x d10	4 x d7	50	PN16	3,10
DN080 (3")	46	89	161,8	22	12	11	F05/F07	70	4 x d10	4 x d7	50	PN16	3,40
DN100 (4")	52	102	178	22	12	14	F07	70	4 x d10			PN16	4,50
DN125 (5")	56	123	190,5	22	12	14	F07	70	4 x d10			PN16	6,40
DN150 (6")	56	138	205,2	22	12	14	F07	70	4 x d10			PN16	7,80
DN200 (8")	60	168	237	34,5	16	17	F10	102	4 x d12			PN16	14,10
DN250 (10")	68	207	268,3	34,5	16	22	F10	102	4 x d12			PN16	19,20
DN300 (12")	78	243,5	308,5	34,5	16	27	F12	125	4 x d14			PN16	29,20

Item 1	Item 2	Item 3	Item 4
Materiaal Huis	Materiaal Zitting	Materiaal Klepblad	Materiaal Bediening
Gietijzer : GG25 + Epoxy coating	EPDM	Roestvrijstaal : CF8M	RVS Spindel AISI 416