

BV38-4545E-PN10

Clapet anti-retour à battant, montage "sandwich" entre brides PN10

Norme d'écartement: Standard d'usine



N° d'article	Réf. Belven
382055N0250	BV38-4545E-PN10-DN250
382055N0300	BV38-4545E-PN10-DN300
382055N0350	BV38-4545E-PN10-DN350
382055N0400	BV38-4545E-PN10-DN400
382055N0450	BV38-4545E-PN10-DN450
382055N0500	BV38-4545E-PN10-DN500
382055N0600	BV38-4545E-PN10-DN600

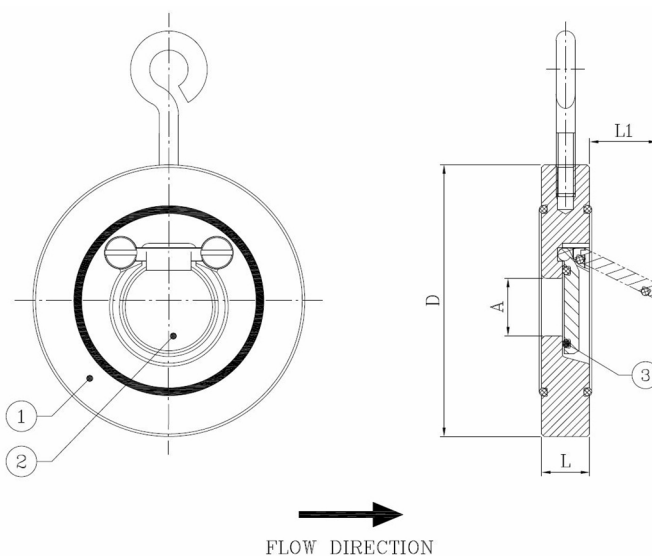

DN/Pouce	L	D	A	L1	Cl. press.	Poids(kg)
DN250 (10")	26	330	192	190	PN10	12,60
DN300 (12")	32	380	227	220	PN10	20,50
DN350 (14")	38	440	266	250	PN10	33,50
DN400 (16")	44	491	310	290	PN10	52,00
DN450 (18")	52	541	350	340	PN10	71,00
DN500 (20")	58	596	400	390	PN10	94,00
DN600 (24")	62	698	486	470	PN10	128,00

Item 1	Item 2	Item 3
Matériau Corps	Matériau Clapet	Matériau Siège
Acier au carbone : 1.0619 (WCB) zingué	Acier au carbone : 1.0619 (WCB) zingué	EPDM