

BV4-4466R-A300 - Dubbelwerkend

Kogelkraan, volle doorlaat, tweedelig huis, geflensd ANSI 300lbs, met dubbelwerkende aandrijving

Norm Bouwlenge: ANSI B16.10

De pneumaat is geselecteerd voor 25°C water met een drukval van 16 bar met een persluchtdruk van 6 bar en minimum 1 schakeling per week



Artikelnummer	Belven Ref.
048A57DA1015	BV4-4466R-A300-DN015 - DA052
048A57DA1020	BV4-4466R-A300-DN020 - DA052
048A57DA1025	BV4-4466R-A300-DN025 - DA063
048A57DA1040	BV4-4466R-A300-DN040 - DA075
048A57DA1050	BV4-4466R-A300-DN050 - DA075
048A57DA1080	BV4-4466R-A300-DN080 - DA100
048A57DA1100	BV4-4466R-A300-DN100 - DA100
048A57DA1150	BV4-4466R-A300-DN150 - DA125

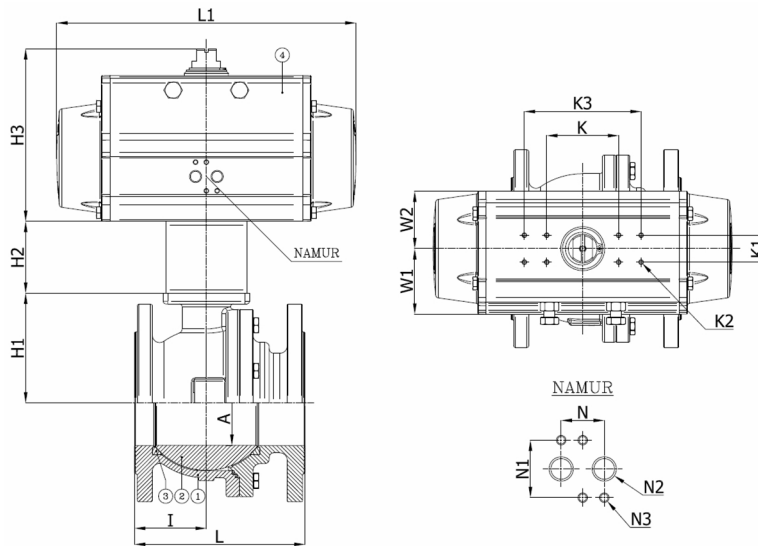

DN/Inch	L	H1	H2	H3	I	L1	W1	W2	K	K3	K1	K2	N	N1	N2	N3	Drukkl.	Gewicht(kg)
DN015 (1/2")	140	33	50	101,5	61,5	141	41	30	80		30	M5	24	32	1/8"	M5	A300	4,00
DN020 (3/4")	152	37	50	101,5	61	141	41	30	80		30	M5	24	32	1/8"	M5	A300	5,40
DN025 (1")	165	45	60	113	70,5	164	45	35,5	80		30	M5	24	32	1/8"	M5	A300	7,60
DN040 (1 1/2")	190	77	60	131	78,5	210	52,5	42	80		30	M5	24	32	1/8"	M5	A300	13,60
DN050 (2")	216	83,5	60	131	86	210	52,5	42	80		30	M5	24	32	1/8"	M5	A300	15,20
DN080 (3")	283	108	80	157,8	81	275	68	55	80		30	M5	24	32	1/4"	M5	A300	31,50
DN100 (4")	305	122	80	157,8	88,5	275	68	55	80	130	30	M5	24	32	1/4"	M5	A300	44,60
DN150 (6")	403	177	100	204,4	172	372	80	68	80	130	30	M5	24	32	1/4"	M5	A300	105,80

Item 1	Item 2	Item 3	Item 4
Materiaal Huis	Materiaal Kogel	Materiaal Zitting	Materiaal Bediening
Koolstofstaal : A216 WCB	Roestvrijstaal : A182-F304 / A351-CF8	RPTFE	Geëxtrudeerd aluminium