

BV3M3-6666T-SW - DSTE met Hendel

3-delige kogelkraan, volle doorlaat, SW lasmoffen DIN 3239-2, ISO 5211 verhoogde top flens, inclusief RVS spindelverlenging met schutbuis en vergrendelbare hendel

Norm Bouwlengte: DIN 3202-4 M3



Artikelnummer	Belven Ref.
03M36977T1S008	BV3M3-6666T-SW - 1/4" - DSTE-LEVER
03M36977T1S010	BV3M3-6666T-SW - 3/8" - DSTE-LEVER
03M36977T1S015	BV3M3-6666T-SW - 1/2" - DSTE-LEVER
03M36977T1S020	BV3M3-6666T-SW - 3/4" - DSTE-LEVER
03M36977T1S025	BV3M3-6666T-SW - 1" - DSTE-LEVER
03M36977T1S032	BV3M3-6666T-SW - 1 1/4" - DSTE-LEVER
03M36977T1S040	BV3M3-6666T-SW - 1 1/2" - DSTE-LEVER
03M36977T1S050	BV3M3-6666T-SW - 2" - DSTE-LEVER

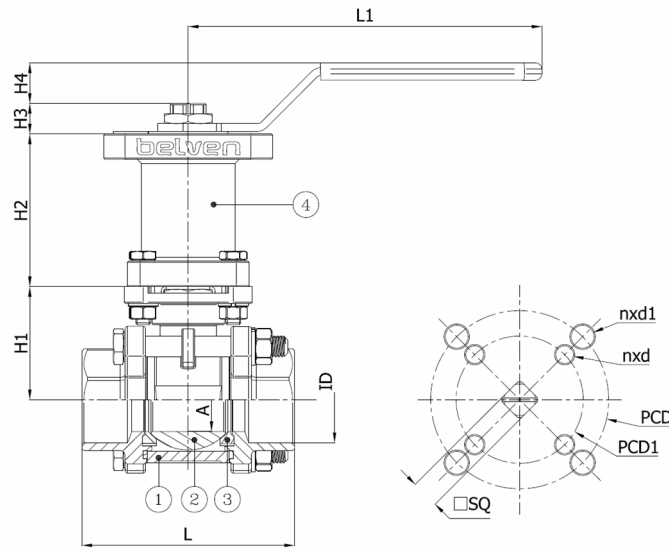

DN/Inch	L	H1	H2	H3	H4	A	I	L1	SQ	ISO	PCD	n x d1	PCD1	ISO1	n x d	Drukkl.	Gewicht(kg)
DN008 (1/4")	55	36	58	9,6	15,5	11,6	14,1	112	9	F05	50				4 x 7	1000 WOG	1,30
DN010 (3/8")	60	36	58	9,6	15,5	12,8	17,6	112	9	F05	50				4 x 7	1000 WOG	1,30
DN015 (1/2")	75	38	58	9,6	15,5	15	21,7	112	9	F05	50				4 x 7	1000 WOG	1,40
DN020 (3/4")	80	41,7	60	11,6	17,3	20	27,2	138	11	F05	50	4 x 9	70	F07	4 x 7	1000 WOG	1,60
DN025 (1")	90	44,4	60	11,6	17,3	25	33,9	138	11	F05	50	4 x 9	70	F07	4 x 7	1000 WOG	1,80
DN032 (1 1/4")	110	52,8	60	11,2	24,4	32	42,6	205	14	F07	70				4 x 9	1000 WOG	2,70
DN040 (1 1/2")	120	58,5	60	11,2	24,4	38	48,7	205	14	F07	70				4 x 9	1000 WOG	3,40
DN050 (2")	140	66	60	11,2	24,4	50	61,1	205	14	F07	70				4 x 9	1000 WOG	4,60

Item 1	Item 2	Item 3	Item 4
Materiaal Huis	Materiaal Kogel	Materiaal Zitting	Materiaal Bediening
Roestvrijstaal : A351 CF8M	Roestvrijstaal : A351 CF8M	PTFE	Roestvrijstaal AISI 316